

# RX-9800-UTC

## PARTS LISTING

NEW AIR CYLINDER PARTS  
STARTING SERIAL NUMBER KS-220318



1. THREAD PICKER ASSEMBLY AND AIR BLOWER

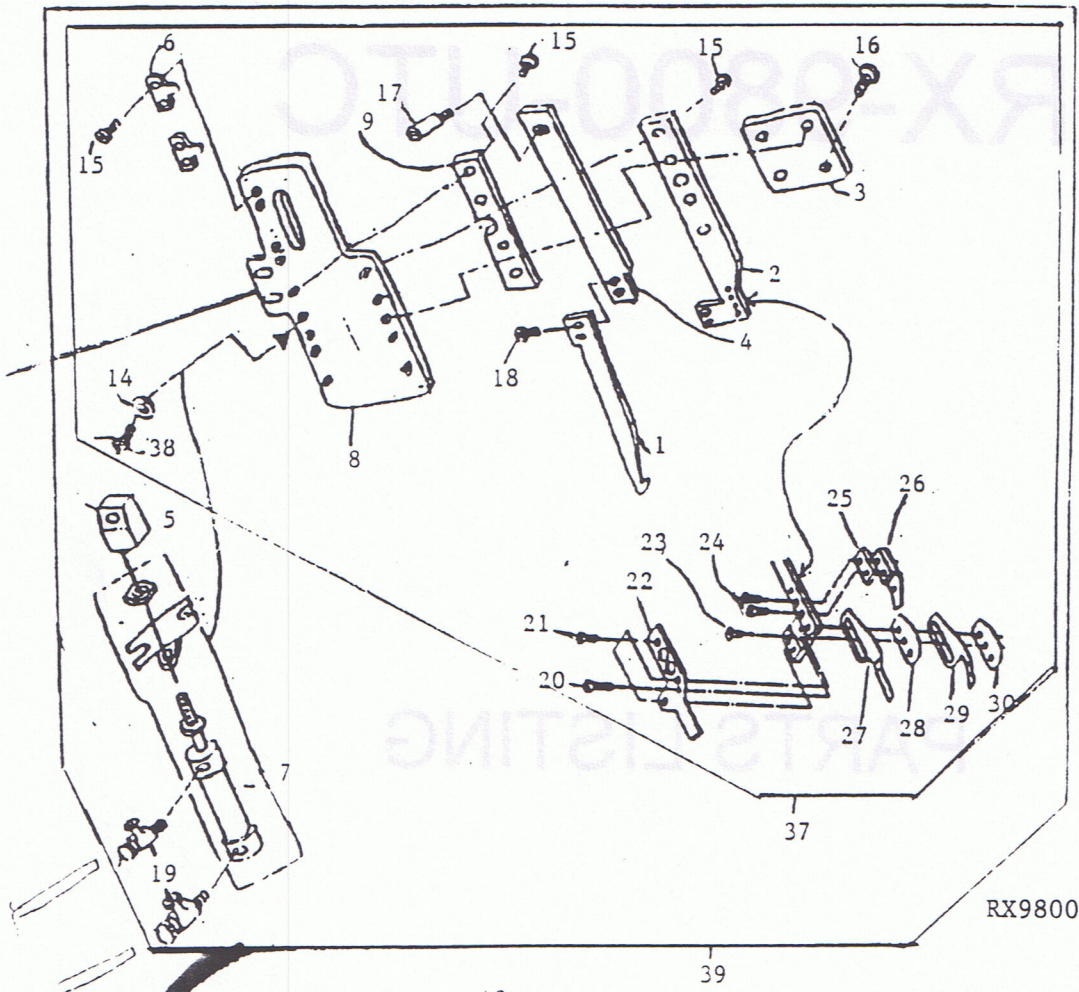

RX9800

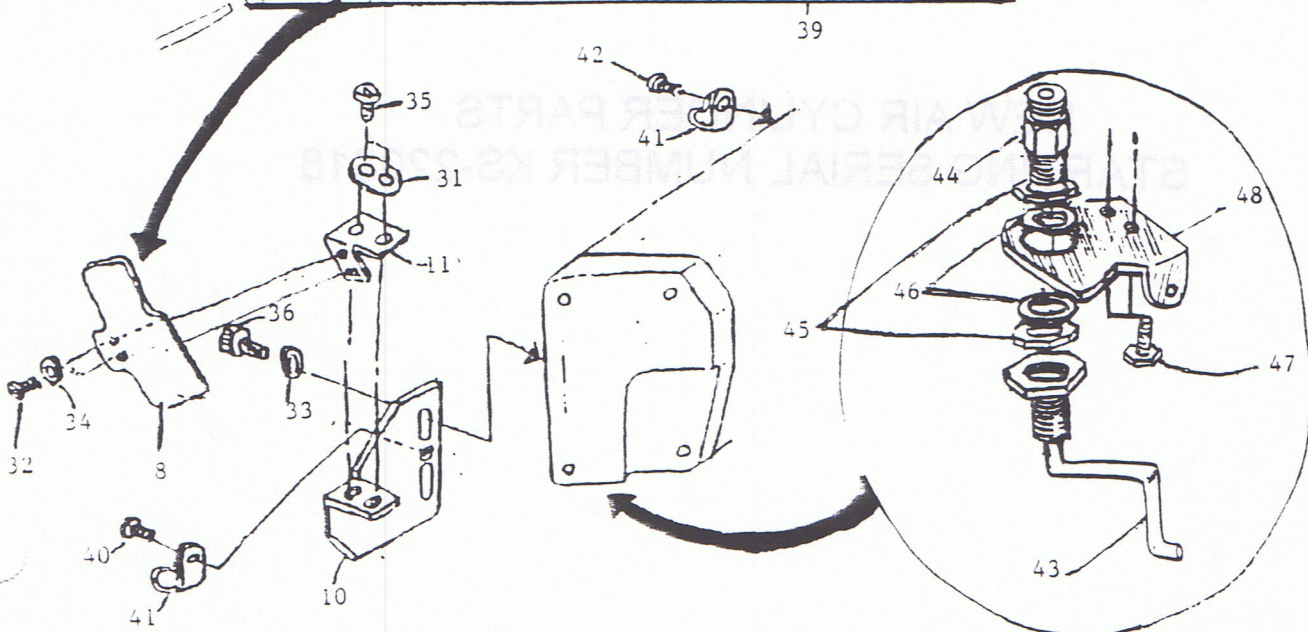

RX9700



1. TOP COVER THREAD CUTTER

REF#	ITEM#	DESCRIPTION	QTY
1	06-351	MOVABLE KNIFE	1
2	06-352	FIXED KNIFE BASE	1
3	06-353	KNIFE PRESSER COVER	1
4	06-354	MOVABLE KNIFE BASE	1
5	06-355	CYLINDER CONNECTING BLOCK	1
6	06-356	STOPPER	2
7	06-584	AIR CYLINDER	1
8	06-358	ATTACHABLE BASE PLATE	1
9	06-359	MOVABLE KNIFE BASE GUIDE	1
10	06-360	KNIFE ASSEMBLY BRACKET	1
11	06-361	ADJUSTMENT BRACKET	1
12			
13			
14	75-468	WASHER	2
15	84-361	SCREW	8
16	84-360	SCREW	2
17	84-573	SCREW	1
18	85-101	SCREW	2
19	06-585	AIR CYLINDER ELBOW	2
20	85-620	SCREW	2
21	85-625	SCREW	2
22	06-632	FIXED KNIFE	1
23	06-601	SCREW	1
24	85-102	SCREW	2
25	06-630	SPRING ADJUSTER SPACE PLATE	1
26	06-602	SPRING ADJUSTER LINER	1
27	06-605	SPRING (WEAK)	1
28	06-603	SPRING LINER	1
29	06-604	SPRING (STRONG)	1
30	06-608	SPRING STOPPER PLATE	1
31	26-712	BASE WASHER	1
32	84-566	SCREW	2
33	75-384	WASHER	2
34	75-455	WASHER	2
35	85-182	SCREW	2
36	87-171	SCREW	2
37	00-806	KNIFE ASSEMBLY	1
38	87-129	SCREW	2
39	00-806-1	KNIFE ASSEMBLY WITH CYLINDER	1
40	87-196	SCREW	1
41	06-929	CODE CLAMP	2
42	84-564	SCREW	1
43	06-175	AIR BLOWER	1
44	09-948	HAFE UNION	1
45	86-801	NUT	2
46	75-538	WASHER	2
47	84-412	SCREW	2
48	05-826	AIR BLOWER BRACKET	1



2. AIR REGULATOR/CYLINDER/BRAKETS

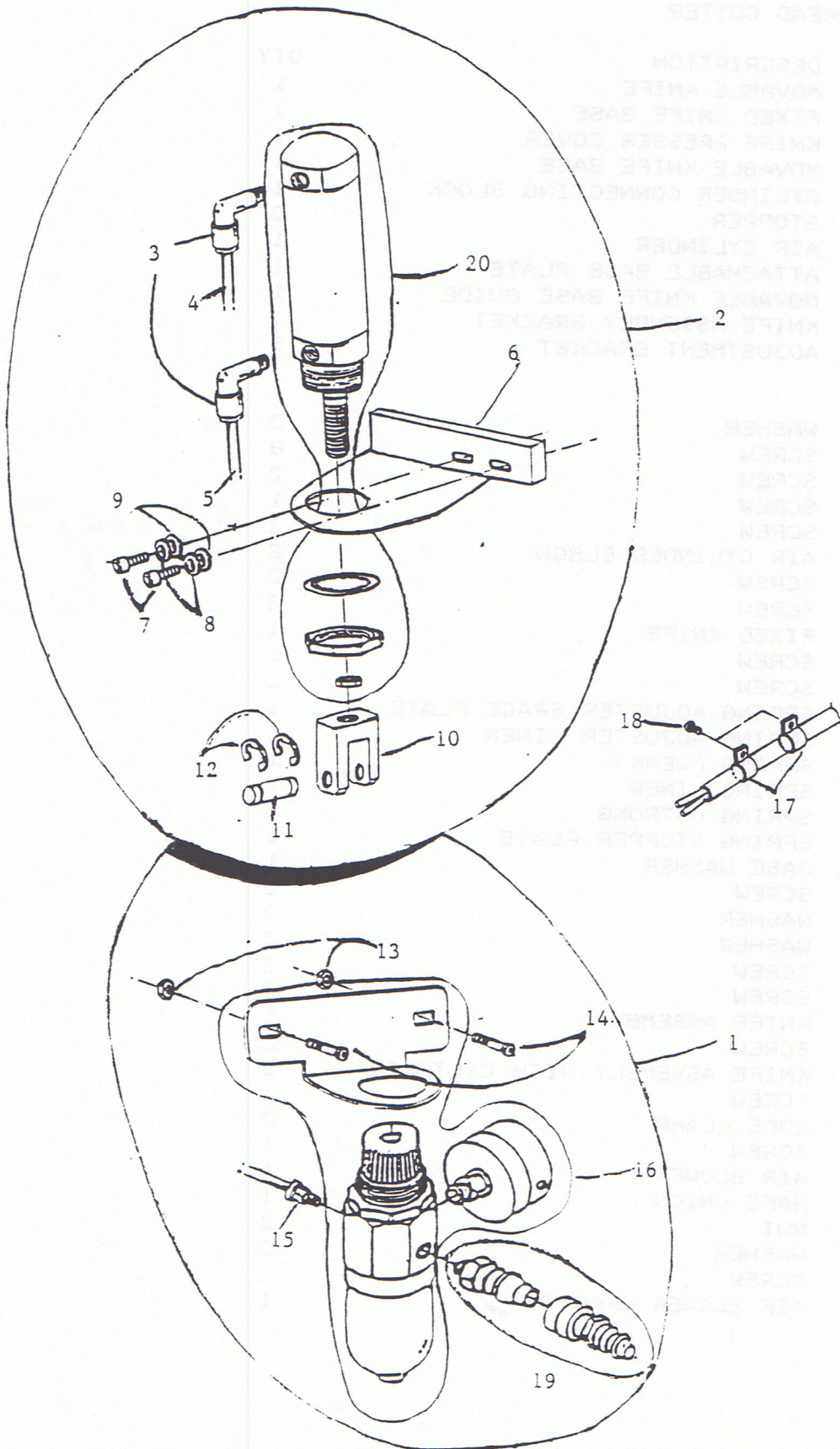



2. AIR REGULATOR/CYLINDER/BRACKETS

REF#	ITEM#	DESCRIPTION	QTY
1	00-601-2	AIR PRESSER CONTROL ASSY	1
2	00-601-3	FOOT LIFTER CYLINDER ASSY	1
3	06-519	L JOINT	2
4	05-864	TUBE	1
5	05-865	TUBE	1
6	05-845	CYLINDER BRACKET	1
7	87-171	SCREW	2
8	75-527	WASHER	2
9	75-357	WASHER	2
10	05-846	Y-KNUCKLE	1
11	05-847	KNUCKLE	1
12	93-211	E-RING	2
13	88-166	NUT	2
14	87-171	SCREW	2
15	06-296	STRAIGHT JOINT	1
16	06-581	AIR PRESSURE CONTROL	1
17	06-929	CODE CLAMP	2
18	84-564	SCREW	2
19	06-517-2	COUPLER SET	1
20	06-582	FOOT LIFTER CYLINDER	1



3. TENSION AND THREAD RELEASE SOLENOID

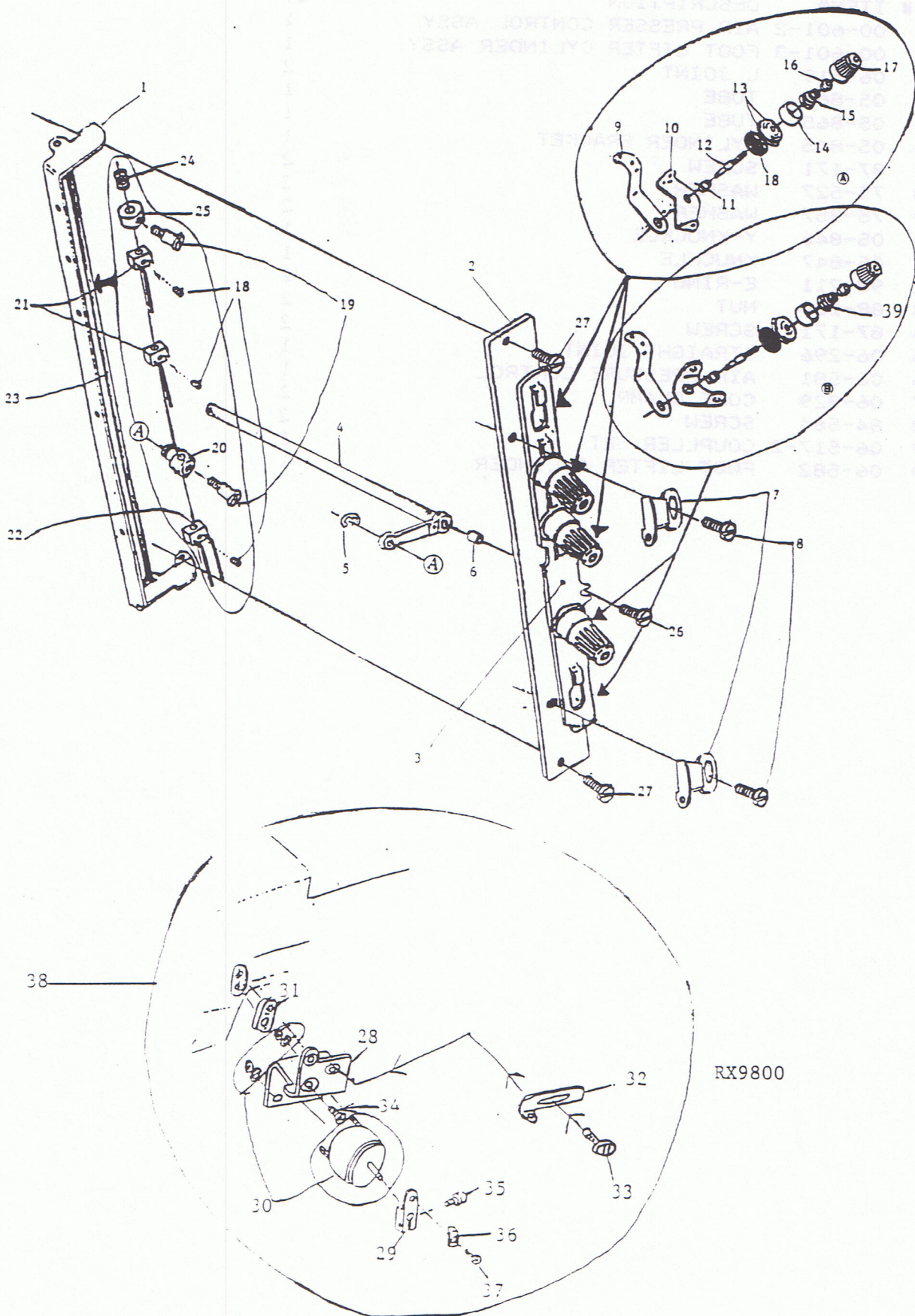



### 3. TENSION & THREAD RELEASE SOLENOID

REF#	ITEM#	DESCRIPTION	QTY	9702	9802	9703	9803
1	05-851	TENSION BRACKET	1				
2	41-501	TENSION PLATE	1				
3	41-502	TENSION HOLDER	1				
4	05-852	CONNECTING LINK	1				
5	93-205	E RING	1				
6	05-852	WASHER	1				
7	45-526	TENSION EYELET	2				
8	84-574	SCREW	2				
9	41-115	TENSION GUIDE A	*	3	4	4	5
10	41-117	TENSION GUIDE B	*	3	4	4	5
11	41-131	TENSION POST FERRULE	*	3	4	4	5
12	41-505	TENSION POST	*	3	4	4	5
13	41-111	TENSION DISC	*	6	8	8	10
14	41-107-W	TENSION CAP	*	3	4	4	5
15	41-701	TENSION SPRING STRONG	*	2	2	3	3
16	41-105	TENSION RATCHET	*	1	2	1	2
17	41-101-W	TENSION CUP	*	3	4	4	5
18	23-324	TENSION CUSHION	*	3	4	4	5
19	84-379	SCREW	2				
20	05-853	THREAD RELEASE CONNECTION	1				
21	05-849	THREAD RELEASE BLOCK	*	2	2	3	3
22	05-850	THREAD RELEASE BLOCK	*	1	2	1	2
23	05-848	THREAD RELEASE BAR	1				
24	79-542	SPRING	1				
25	75-540	COLLAR	1				
26	84-567	SPRING	1				
27	84-575	SPRING	2				
28	06-363	SOLENOID BRACKET	1				
29	06-364	SOLENOID LEVER	1				
30	06-365	RETOARY SOLENOID	1				
31	06-366	SPACER	1				
32	47-132	EYELET	1				
33	84-361	SCREW	1				
34	83-200	SCREW	2				
35	87-113	SCREW	1				
36	43-519	EYELET	1				
37	84-364	SCREW	1				
38	00-807-1	SOLENOID ASSEMBLY	1				
39	41-702	TENSION SPRING WEAK	*	1	2	1	2



# 4. AIR CYLINDER ASSEMBLY

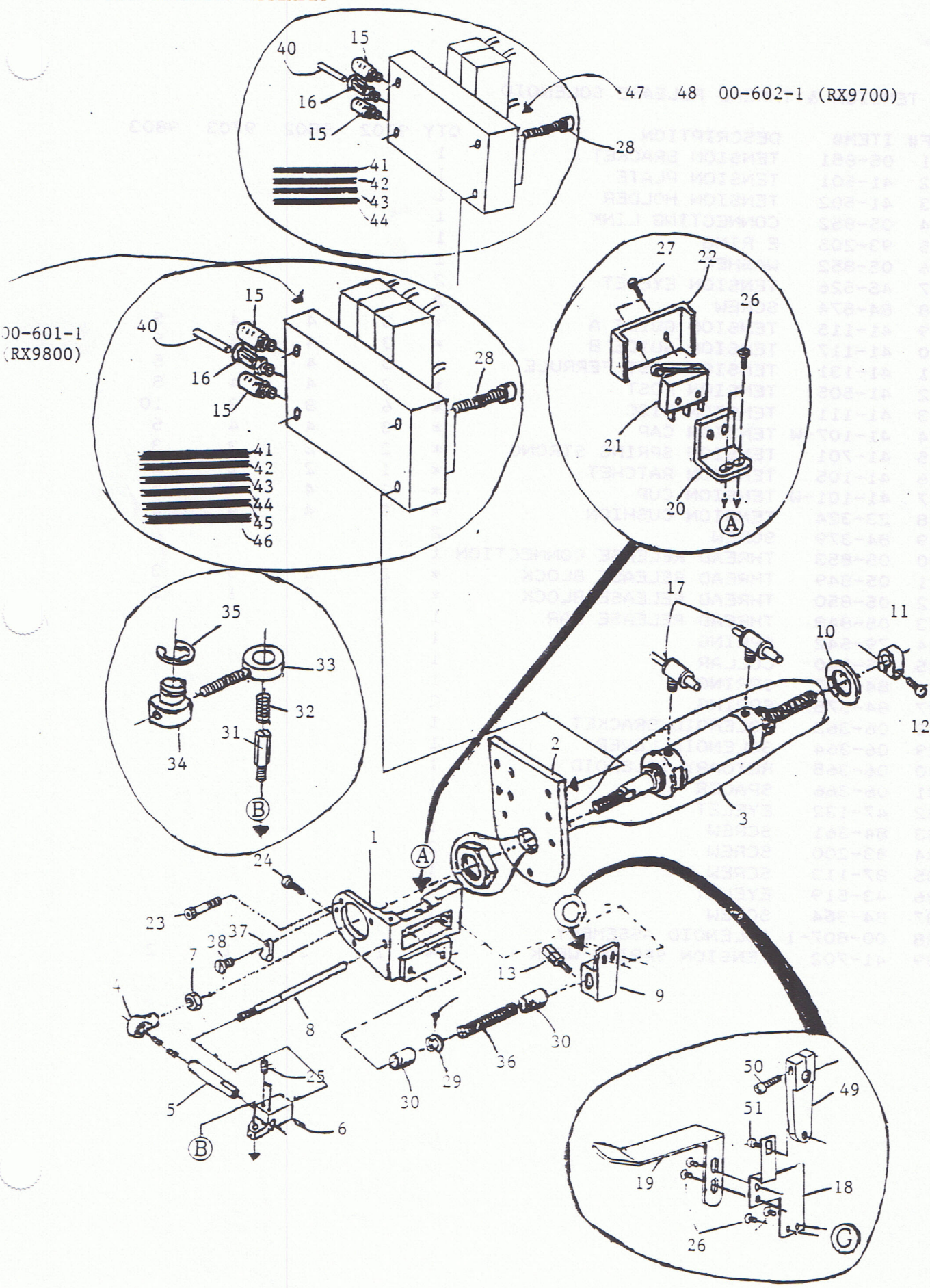



4. AIR CYLINDER ASSEMBLY

REF#	ITEM#	DESCRIPTION	QTY
1	05-901	CYLINDER BRACKET	1
2	05-902	CYLINDER PLATE	1
3	06-576	KNIFE DRIVING AIR CYLINDER	1
4	05-903	ROD RED	1
5	05-904	CONNECTING SHAFT	1
6	05-828	CONNECTING BRACKET	1
7	88-176	NUT	1
8	05-905	SHAFT	1
9	05-906	BRACKET	1
10	05-907	CUSHION RUBBER	1
11	75-548	CUSHION STOPPER	1
12	87-245	SCREW	1
13	84-612	SCREW	1
14	06-577	SOLENOID RX9800	1
15	06-578	MUFFLER	2
16	06-579	STRAIGHT JOINT	1
17	06-580	SPEED CONTROLLER	2
18	05-908	THREAD RELEASE CONNECTING PLATE	1
19	05-909	SWITCH GUIDE	1
20	05-910	SWITCH PLATE	1
21	05-911	SWITCH	1
22	05-912	SWITCH COVER	1
23	87-213	SCREW	3
24	87-171	SCREW	2
25	84-521	SCREW	2
26	87-284	SCREW	6
27	87-282	SCREW	2
28	87-283	SCREW	4
29	93-222	E-RING	1
30	52-177	BUSHING	2
31	05-829	CONNECTING PIN B	1
32	79-540	CONNECTING PIN SPRING	1
33	05-913	CONNECTING SCREW	1
34	05-914	CONNECTING PIN A	1
35	93-211	E-RING	1
36	79-641	SPRING	1
37	06-928	NYLON CLIP	1
38	87-196	SCREW	1
39	00-601-1	AIR CYLINDER ASSEMBLY RX9800	1
40	05-917	TUBE 1500MM	1
41	05-918	TUBE 150MM	1
42	05-919	TUBE 80MM	1
43	05-920	TUBE 280MM	1
44	05-921	TUBE 210MM	1
45	05-922	TUBE 770MM RX9800	1
46	05-923	TUBE 760MM RX9800	1
47	06-589	SOLENOID RX9700	1
48	00-602-1	AIR CYLINDER ASSEMBLY RX9700	1
49	05-840	CRANK LEVER	1
50	87-245	SCREW	1
51	84-562	SCREW	1



5. NEW KNIFE ASSEMBLY (STARTING SERIAL NUMBER 210028)

13-----COMPLETE KNIFE ASSEMBLY

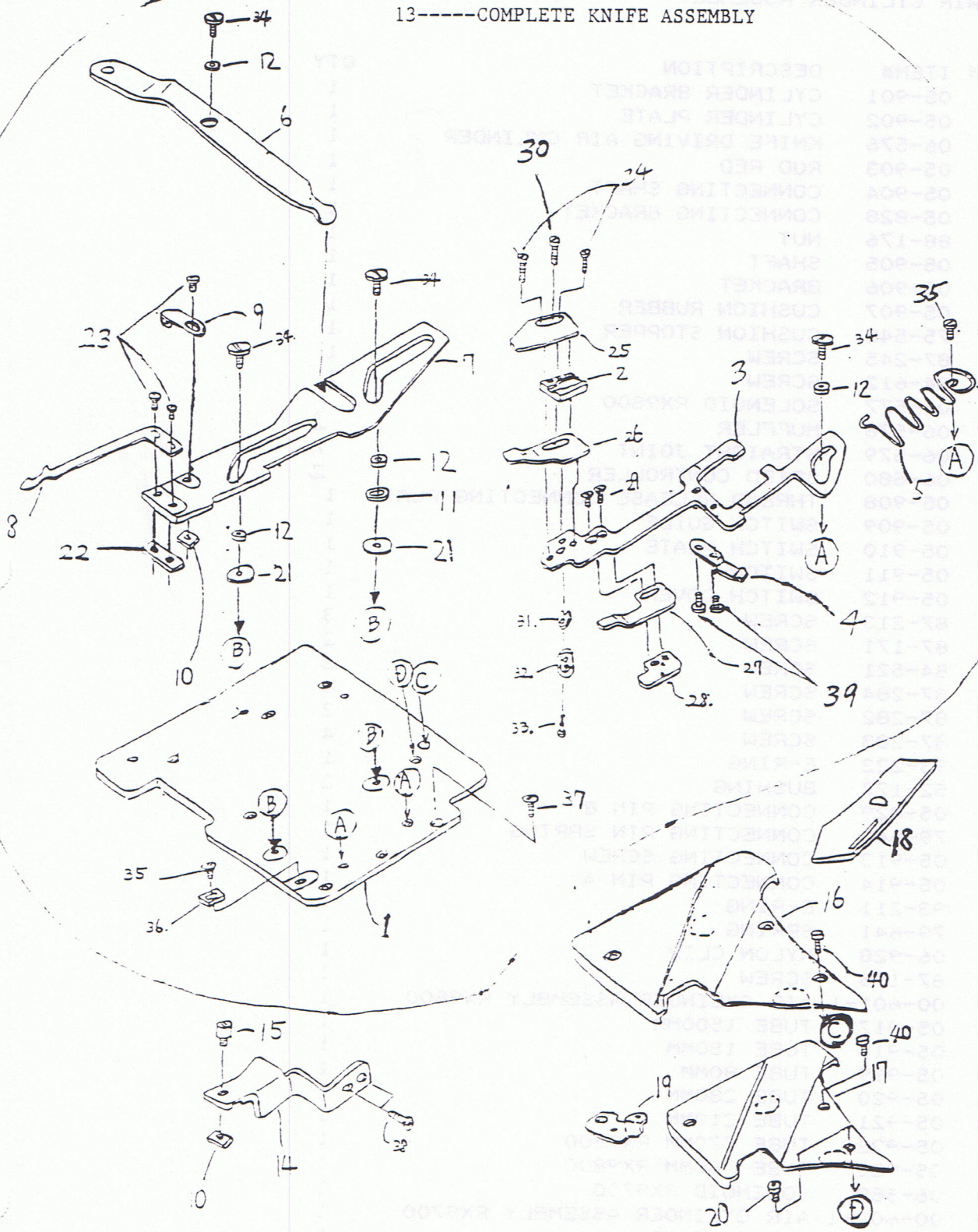



AIR CYLINDER PARTS CHANGE OVER NOT INTERCHANGEABLE  
UNLESS ORDERED AS ASSEMBLY

OLD ITEM#	NEW ITEM#		DESCRIPTION	QTY
05-827	05-901		CYLINDER BRACKET	1
05-839	05-902		CYLINDER PLATE	1
06-279	06-576		KNIFE DRIVING AIR CYLINDER	1
05-842	05-903		ROD RED	1
05-843	05-904		CONNECTING SHAFT	1
05-828	05-828	same	CONNECTING BRACKET	1
88-176	88-176	same	NUT	1
05-841	05-905		SHAFT	1
05-836	05-906		BRACKET	1
05-837	05-907		CUSHION RUBBER	1
75-539	75-548		CUSHION STOPPER	1
87-245	87-245	same	SCREW	1
84-612	84-612	same	SCREW	1
06-277 X3	06-577		SOLENOID RX9800	1
06-515	06-578		MUFFLER	2
06-296	06-579		STRAIGHT JOINT	1
06-508	06-580		SPEED CONTROLLER	2
05-832	05-908		THREAD RELEASE CONNECTING PLATE	1
new	05-909		SWITCH GUIDE	1
05-834	05-910		SWITCH PLATE	1
05-844	05-911		SWITCH	1
05-833	05-912		SWITCH COVER	1
87-245	87-213		SCREW	3
87-171	87-171	same	SCREW	2
84-521	84-521	same	SCREW	2
84-361 X2	87-284		SCREW	6
84-574 X2				
new	87-282		SCREW	2
87-215	87-283		SCREW	4
75-001-1	93-222		E-RING	1
new	52-177		BUSHING	2
79-540	05-829	same	CONNECTING PIN B	1
05-830	79-540	same	CONNECTING PIN SPRING	1
05-831	05-913		CONNECTING SCREW	1
79-554	05-914		CONNECTING PIN A	1
79-541	93-211		E-RING	1
06-935	79-641		SPRING	1
87-196	06-928		NYLON CLIP	1
new	87-196	same	SCREW	1
new	00-601-1		AIR CYLINDER ASSEMBLY RX9800	1
new	05-917		TUBE 1500MM	1
new	05-918		TUBE 150MM	1
new	05-919		TUBE 30MM	1
new	05-920		TUBE 280MM	1
new	05-921		TUBE 210MM	1
new	05-922		TUBE 770MM RX9800	1
new	05-923		TUBE 760MM RX9800	1
new	06-589		SOLENOID RX9700	1
new	00-602-1		AIR CYLINDER ASSEMBLY RX9700	1



5. NEW KNIFE ASSEMBLY (STARTING SERIAL NUMBER 210028)

REF#	ITEM#	DESCRIPTION	QTY
1	05-871	KNIFE BASE PLATE	1
2	05-872	MOVABLE KNIFE GUIDE	1
3	05-873	FIXED KNIFE BASE	1
4	05-874	GUIDE SPRING	1
5	05-875	SPRING	1
6	05-876	DRIVE LEVER	1
7	05-877	MOVABLE KNIFE BASE	1
8	05-878	MOVABLE KNIFE	1
9	05-879	EYELET	1
10	05-880	NUT	2
11	05-881	GUIDE ROLLER LARGE	1
12	05-882	GUIDE ROLLER SMALL	4
13	00-805-5	KNIFE ASSEMBLY	1
14	05-883	GUIDE BRACKET	1
15	05-884	GUIDE PIN	1
16	21-678	UPPER BASE COVER**	1
17	21-675	UPPER BASE COVER**	1
18	21-679	SLIDE PLATE	1
19	43-515	EYELET	1
20	87-092	SCREW**	1
21	05-885	SPACE WASHER	2
22	05-886	PLATE SPRING STOPPER PLATE	1
23	87-077	SCREW	3
24	87-078	SCREW	2
25	05-812	FIXED KNIFE	1
26	05-814	UPPER SPRING	1
27	05-815	LOWER SPRING	1
28	05-822	BRACKET	1
29	87-107	SCREW	2
30	87-079	SCREW	1
31	05-817	SPACER	1
32	05-818	SPRING ADJUST PLATE	1
33	05-819	RIVET	1
34	87-076	SCREW	4
35	84-167	SCREW	2
36	05-800	FIXED KNIFE STOPPER	1
37	84-661	SCREW	7
38	84-574	SCREW	2
39	87-091	SCREW	2
40	87-113	SCREW**	3
40	87-113	SCREW**	2

\*\*21-678 IS THE NEWEST UPPER CLOTH PLATE  
USE WITH 3 PCS OS OF 87-113.

\*\*21-675 IS THE UPPER CLOTH PLATE TO USE  
WITH A NEW KNIFEIFE UNIT TO BE INSTALLED ON  
OLD STYLE UTC MACHINES. 2 PCS OF 87-113 & 1 P1 PC  
OF 87-092 ARE USED TO HOLD PLATE.